



8 3/4" ETA 956.612

CT 956612 ESI 412327 07 14.05.2014

8 3/4" Ø 19,40 mm

Movement height	Altura sobre máquina	Altezza sopra movimento	2,50 mm
Height on battery	Altura sobre pila	Altezza sopra pila	4,50 mm
Number of jewels	Número de piedras	Numero di pietre	7
Frequency	Frecuencia	Frequenza	32'768 Hz

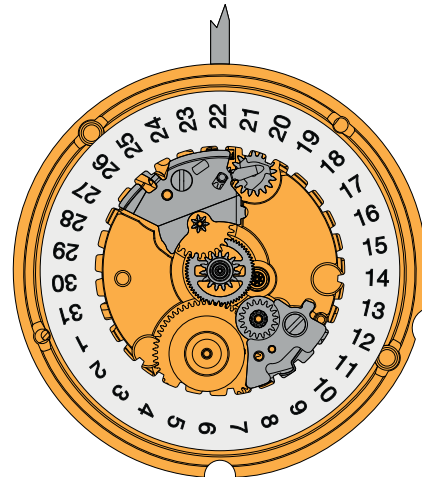
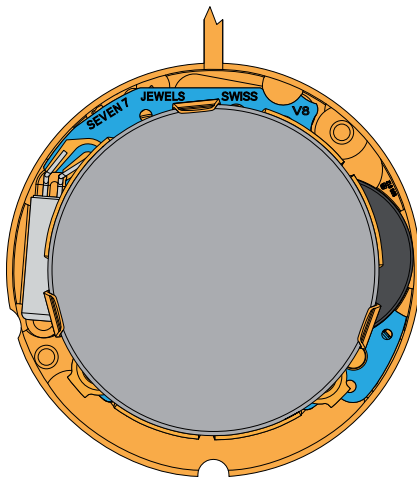

The repair and reconditioning work must only be performed by properly trained personnel.
Las tareas de reparación y revisión sólo deben ser llevadas a cabo por personal debidamente formado.
I lavori di riparazione e di revisione devono essere eseguiti esclusivamente da personale adeguatamente formato.



General information



Before starting work, please study this "Technical communication" carefully.



Eye protection is obligatory for all operations / work on the movement!



ETA SA disclaims any liability in case of damage arising from failure to observe this "Technical communication".

Environmental protection requirements



The legal provisions relating to waste handling and disposal must be observed in all operations / work on the movement!

In particular, lubricating and cleaning products harmful to the environment must be disposed of in accordance with the rules!



Substances prone to cause water pollution must be stored, transported, collected and disposed of in appropriate vessels.

Under no circumstances must they pollute the soil or be poured into sewage systems!

Explanation of symbols



Caution! Risk of material damage!

Below are some obligatory instructions for preventing any material damage!

Información general



Esta "Comunicación técnica" deberá estudiarse muy bien **antes** de comenzar los trabajos.



Es obligatorio utilizar protección ocular para todos los trabajos en y con el reloj.



ETA SA no se hace responsable de los daños provocados como consecuencia de la inobservancia de esta "Comunicación técnica".

Normas de protección medioambiental



Deberá cumplirse la normativa legal relativa al reciclaje y la eliminación correctos de los residuos en todos los trabajos en y con el reloj.

En especial, deberán eliminarse correctamente los productos lubricantes y de limpieza peligrosos para el medio ambiente.



Las sustancias contaminantes del agua deben recogerse, almacenarse, transportarse y eliminarse en recipientes adecuados.

En ningún caso se permitirá que contaminen el suelo o que lleguen a la canalización.

Significado de los símbolos



Atención Peligro de daños materiales

Instrucciones que deberán respetarse necesariamente para evitar daños materiales.

Informazioni generali



Questa "Comunicazione Tecnica" deve essere studiata attentamente **prima** dell'inizio dei lavori.



Per tutti i lavori su e con il movimento dell'orologio è obbligatorio proteggere gli occhi!



ETA SA declina qualunque responsabilità per eventuali danni causati dalla mancata osservanza della presente "Comunicazione tecnica".

Disposizioni relative alla protezione ambientale



Per tutti i lavori su e con il movimento dell'orologio si dovranno rispettare le disposizioni di legge relative al corretto riciclaggio e smaltimento dei rifiuti!

In particolare si dovrà provvedere al corretto smaltimento di lubrificanti e detergenti nocivi per l'ambiente!



Le sostanze inquinanti per l'acqua devono essere conservate, trasportate, raccolte e smaltite in contenitori adatti.

Queste non devono inquinare il terreno o arrivare nelle canalizzazioni!

Spiegazione dei simboli



Attenzione! Pericolo di danni materiali!

Seguono importanti indicazioni che devono essere tassativamente rispettate per evitare danni materiali!

List of components - Lista de piezas - Lista fornitori

Pos	No	No CS	Article number Número de artículo Numero articolo		List of components	Lista de piezas	Lista fornitori
1	100/1	10.020.06	Var		Main plate, montiert	Platina, montada	Piastra, montata
1-1	144	10.300.00	7613226056893		Dial fastener	Sujetador de esfera	Ferma-quadrante
1-2	4021	20.582.00	7613226008885		Stator	Estátor	Statore
1-3	4070	80.244.00	7613226040724		Contact rivet	Remache de contacto	Ribattino di contatto
2	407	31.121.00	7613226001572		Sliding pinion	Piñón corredizo	Pignone scorrevole
3	405	51.020.00	7613226034853		Handsetting stem	Tija de puesta en hora	Albero di messa all'ora
4	2648	53.061.00	7613226007994		Corrector lever	Palanquita de corrector	Leva del correttore
5	443/1	51.080.06	7613226009370		Setting lever, assembled	Tirete, montado	Tiretto, montato
6	549	81.185.00	7613226051997		Setting lever spring-clip	Chaveta de tirete	Chiavetta del tiretto
7	445	51.090.00	7613226056848		Setting lever jumper	Muelle flexible de tirete	Scatto del tiretto
8	4211	20.580.06	7613226048317		Rotor, assembled	Rotor, montada	Rotore, montata
9	210	30.025.00	7613226031098		Third wheel	Rueda primera	Ruota mediana
10	227	30.027.00	Var		Second wheel	Rueda de segundos	Ruota dei secondi
11	203	30.012.06	7613226043794		Intermediate wheel, assembled	Rueda intermedia, montada	Ruota intermedia, montata
12	110	10.048.07	Var		Train wheel bridge, jewelled	Puente de rodaje empedrado	Ponte del ruotismo con pietre
13	560	56.071.00	7613226014299		Centre second stop lever	Palanquita de parada de segundos al centro	Leva d'arresto dei secondi al centro
14	4072	80.209.00	7613226052581		Distance piece for bridel -	Tirante de brida -	Spessore della brida -
15	4000	10.513.00	7613226084469		Electronic module	Módulo electrónico	Modulo elettronico
16	4407	20.764.00	7613226000322		Bridle +	Brida +	Brida +
17	242	31.083.00	Var		Cannon pinion with driving wheel	Cañón de minutos con rueda de arrastre	Pignone calzante con ruota conduttrice
18	260	31.041.06	7613226011212		Minute wheel, assembled	Rueda de minutería, montada	Ruota della minutería, montata
19	450	31.100.00	7613226041097		Setting wheel	Rueda de transmisión	Rinvio
20	2566	53.200.06	7613226053991		Date corrector, monté	Corrector de fecha, montiert	Correttore della data, assembled
21	435	51.050.00	7613226055292		Yoke	Báscula de piñón corredizo	Bascula del pignone scorrevole
22	462	10.062.00	7613226004719		Minute train bridge	Puente de rodaje de minutería	Ponte del ruotismo di minutería
23	2557/1	91.440.22	Var		Date indicator	Indicador de fecha	Indicatore della data
24	2556	33.020.06	7613226016569		Date indicator driving wheel, assembled	Rueda de arrastre del indicador de fecha, montada	Ruota conduttrice dell'indicatore della data, montata
25	2543	33.011.00	7613226003668		Intermediate date wheel	Rueda intermedia de fecha	Ruota intermedia del datario
26	2576	53.080.00	7613226084568		Date jumper	Muelle flexible de fecha	Scatta-data
27	2595	13.111.00	7613226047037		Date jumper maintaining plate	Placa de sujeción del muelle flexible de fecha	Placca di guardia dello scatta-data
28	255/1	31.046.06	Var		Hour wheel, assembled	Rueda de horas, montada	Ruota delle ore, montata
29	259	81.171.00	7613226006898		Hour wheel spring-clip	Chaveta de rueda de minutería	Chiavetta della ruota di minutería
30	4046	20.651.00	7613226057012		Battery insulator	Aislante de pila	Isolatore della pila
31	4929	20.570.00	7613226105119		Battery, 16.00 x 1.60 mm	Aislante de pila, 16,00 x 1,60 mm	Isolatore della pila, 16,00 x 1,60 mm
900	-	88.502.00	7613226105010	1x	Cylindrical head screw - Pos. 12: Screw for train wheel bridge	Tornillo de cabeza cilíndrica - Pos. 12: Tornillo de puente de rodaje	Vite e testa cilíndrica - Pos. 12: Vite del ponte del ruotismo
901	-	88.542.00	7613226123564	2x	Countersunk head screw - Pos. 16: Screw for electronic module, long	Tornillo de cabeza cónica - Pos. 16: Tornillo para brida + largo	Vite a testa conica - Pos. 16: Vite per brida + lunga
902	-	88.542.00	7613226123557	1x	Countersunk head screw - Pos. 16: Screw for electronic module, short	Tornillo de cabeza cónica - Pos. 16: Tornillo para brida + corto	Vite a testa conica - Pos. 16: Vite per brida + corto
903		88.542.00	7613226088597	1x 1x	Countersunk head screw - Pos. 22: Screw for minute train bridge - Pos. 27: Screw for date jumper maintaining plate	Tornillo de cabeza cónica - Pos. 22: Tornillo de puente de rodaje de minutería - Pos. 27: Tornillo para placa de sujeción del muelle flexible de fecha	Vite a testa conica - Pos. 22: Vite del ponte del ruotismo di minutería - Pos. 27: Vite per placca di guardia dello scatta-data

Interchangeability and variants can be found on the **ETA ONLINE SHOP (EOS):**

www.eta.ch

- Support Center
- Support Center Portal

La intercambiabilidad y las variantes se encuentran en **ETA ONLINE SHOP (EOS):**

www.eta.ch

- Support Center
- Support Center Portal

L'intercambiabilità e le varianti si trovano sul **ETA ONLINE SHOP (EOS):**

www.eta.ch

- Support Center
- Support Center Portal

Materials - Fornituras - Forniture

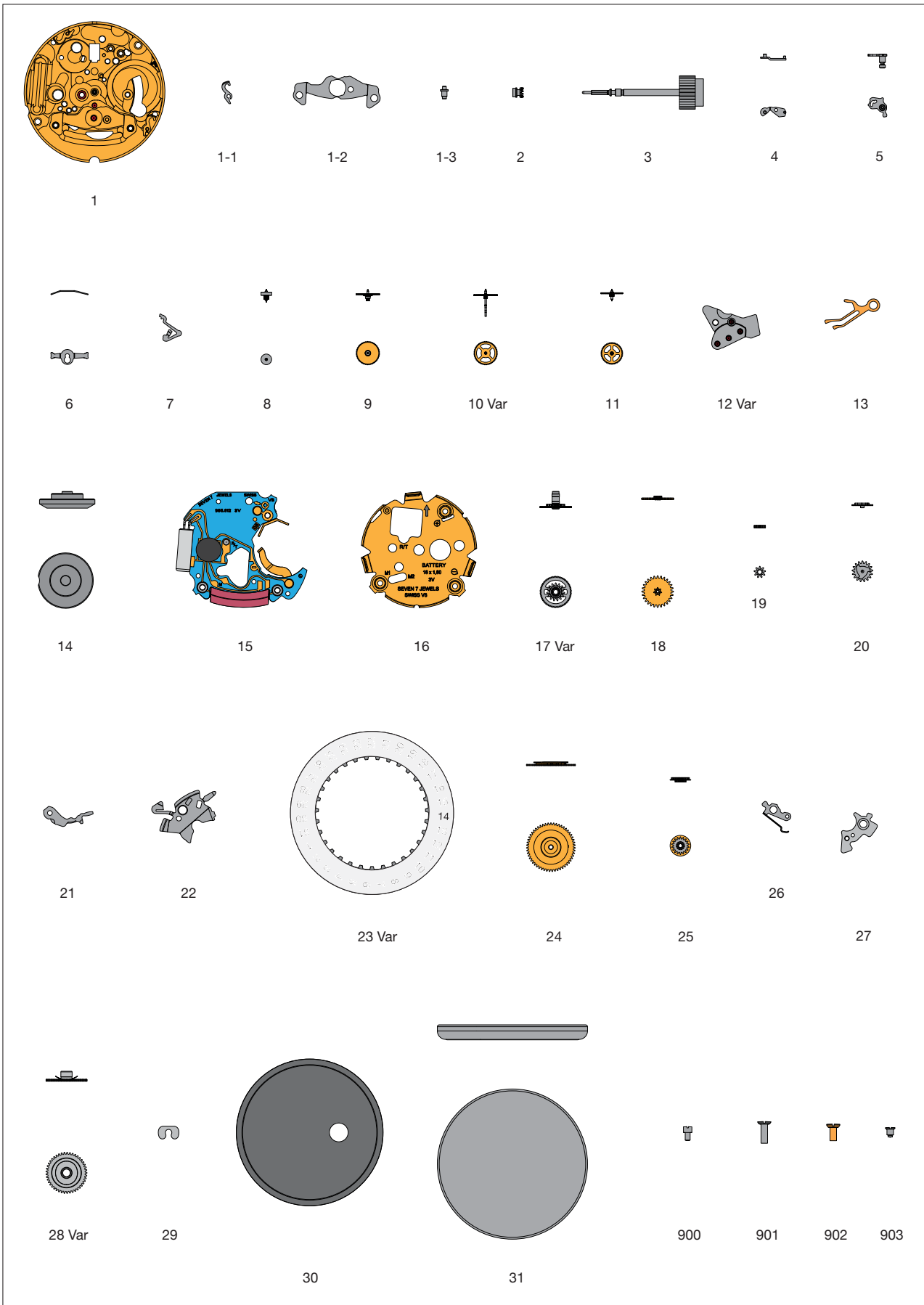

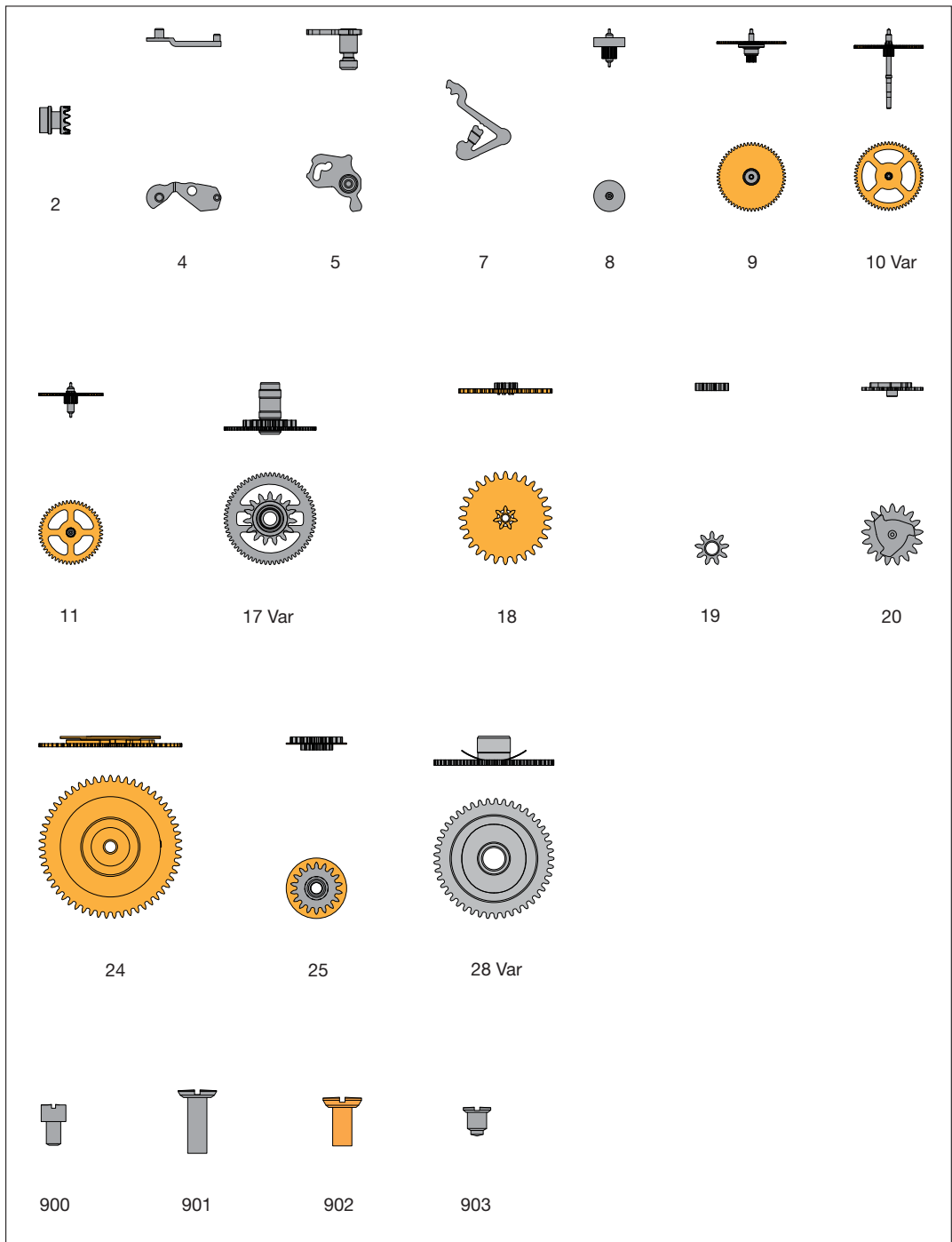

Order of assembly - Orden del montaje - Ordine dell'assemblaggio:
 Handsetting mechanism - Mecanismo de puesta en hora - Meccanismo della messa all'ora

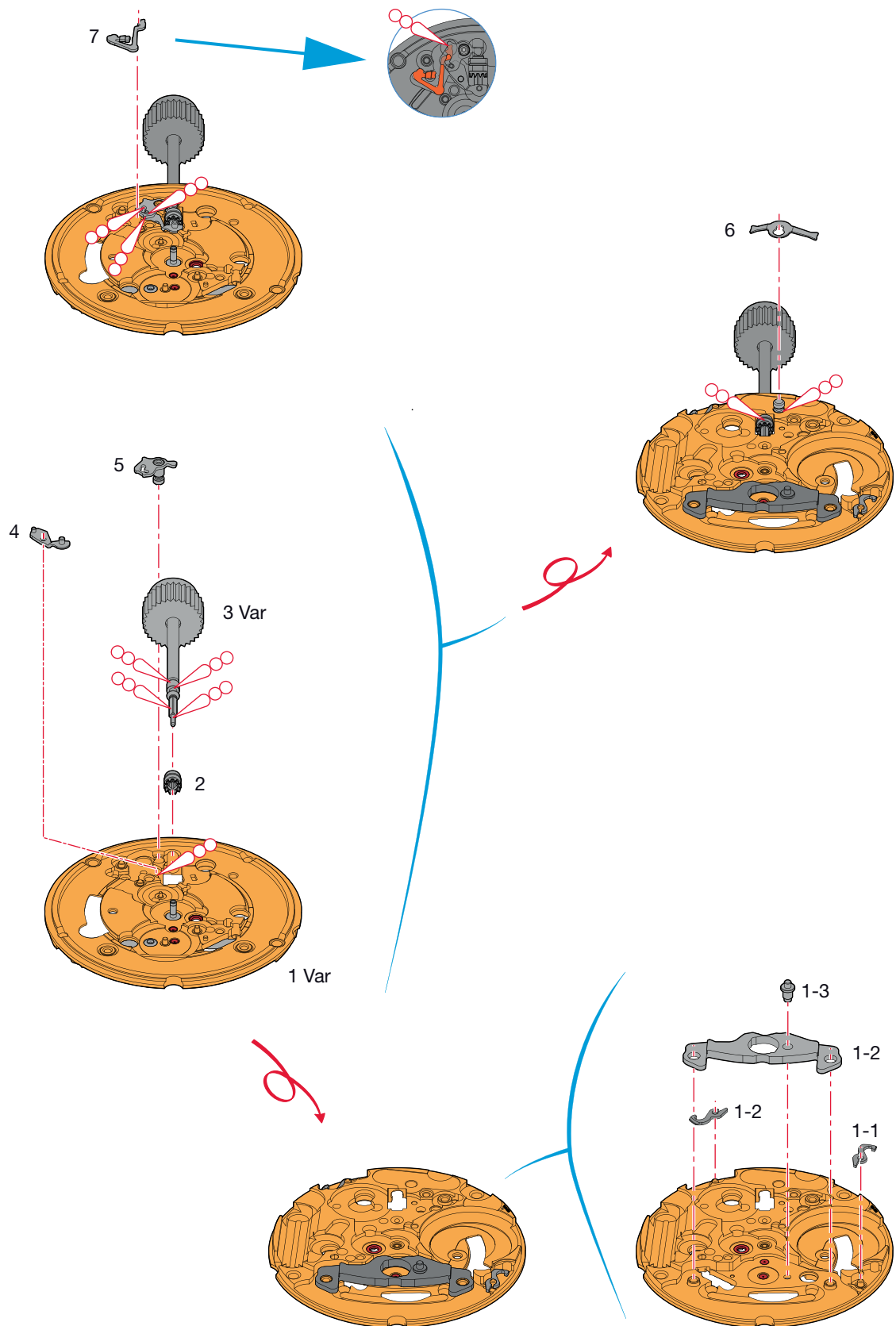

Assembling of the handsetting mechanism

(Parts listed in order of assembly)

Montaje del mecanismo de puesta en hora

(Lista de fornitureas por orden de ensamblado)

Montaggio del meccanismo della messa all'ora

(Elenco delle forniture in ordine di montaggio)

1	4	7
2	5	
3	6	

Lubrication - Lubricación - Lubrificazione

Thick oil or grease
Aceite espeso o grasa
Olio denso o grasso

Moebius
HP-1300
or / ó / o
Moebius D5

M_L Minimum torque for loosening**M_L Par mínimo para desatornillar****M_L Coppia minima per svitare**

(a) 0,7 Ncm

Order of assembly - Orden del montaje - Ordine dell'assemblaggio:
Basic movement - Máquina de base - Movimento di base

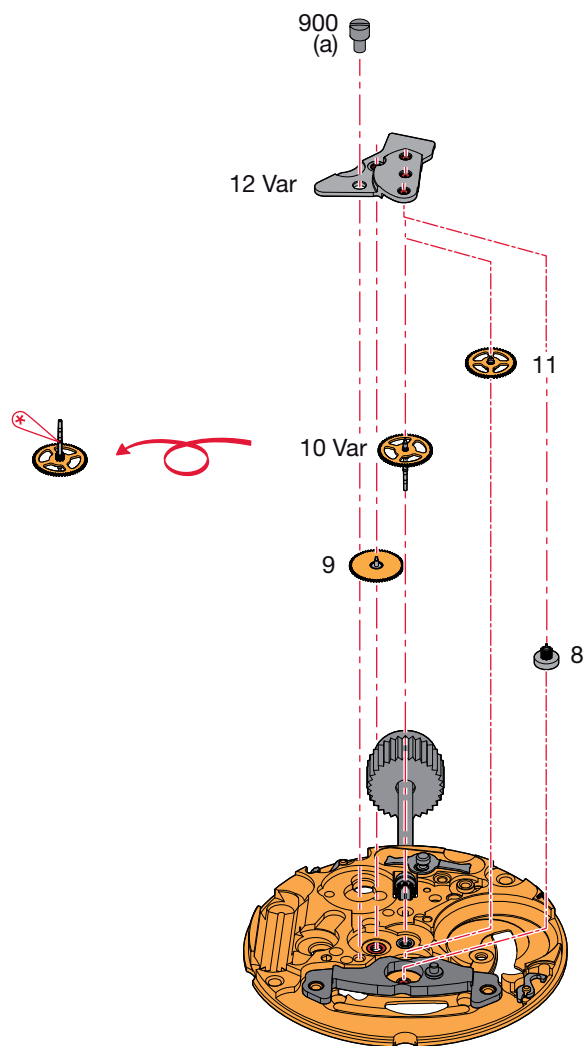

Assembling of the basic movement

(Parts listed in order of assembly)

Montaje de la máquina de base

(Lista de fornitureas por orden de ensamblado)

Montaggio del movimento di base

(Elenco delle forniture in ordine di montaggio)

8	10 Var	12 Var
9	11	900 (1x)

Lubrication - Lubricación - Lubrificazione

	Very small quantity	Moebius 9014
	Cantidad muy pequeña	or / ó / o
	Piccolissima quantità	Moebius 9034

M_L Minimum torque for loosening**M_L Par mínimo para desatornillar****M_L Coppia minima per svitare**

(a) 0,7 Ncm

Order of assembly - Orden del montaje - Ordine dell'assemblaggio:
Electronic module - Módulo electrónico - Modulo elettronico

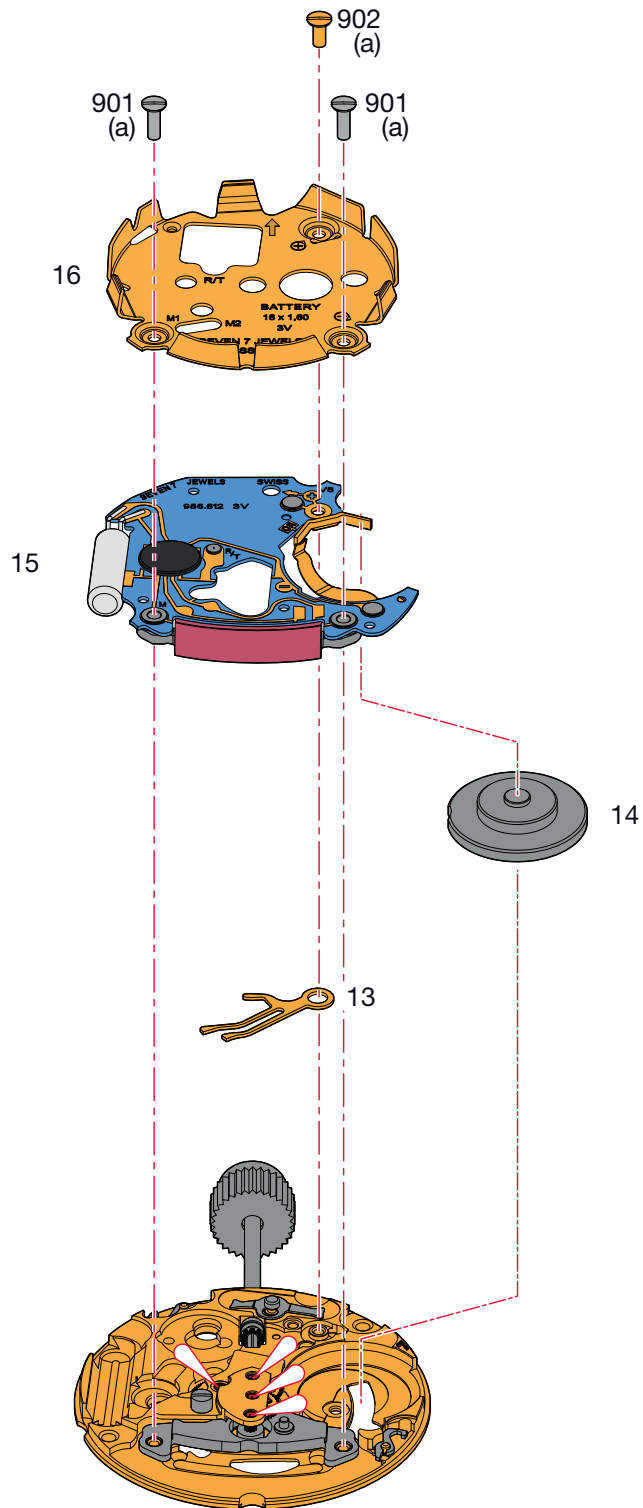

Assembling of the electronic module

(Parts listed in order of assembly)

Montaje del módulo electrónico

(Lista de fornitureas por orden de ensamblado)

Montaggio del modulo elettronico

(Elenco delle forniture in ordine di montaggio)

13	15	901 (2x)
14	16	902 (1x)

Lubrication - Lubricación - Lubrificazione

	Fine oil	Moebius 9014
	Aceite fino	or / ó / o
	Olio fluido	Moebius 9034

M_L Minimum torque for loosening**M_L Par mínimo para desatornillar****M_L Coppia minima per svitare**

(a) 0,7 Ncm

Order of assembly - Orden del montaje - Ordine dell'assemblaggio:
 Calendar mechanism - Mecanismo del calendario - Meccanismo del calendario

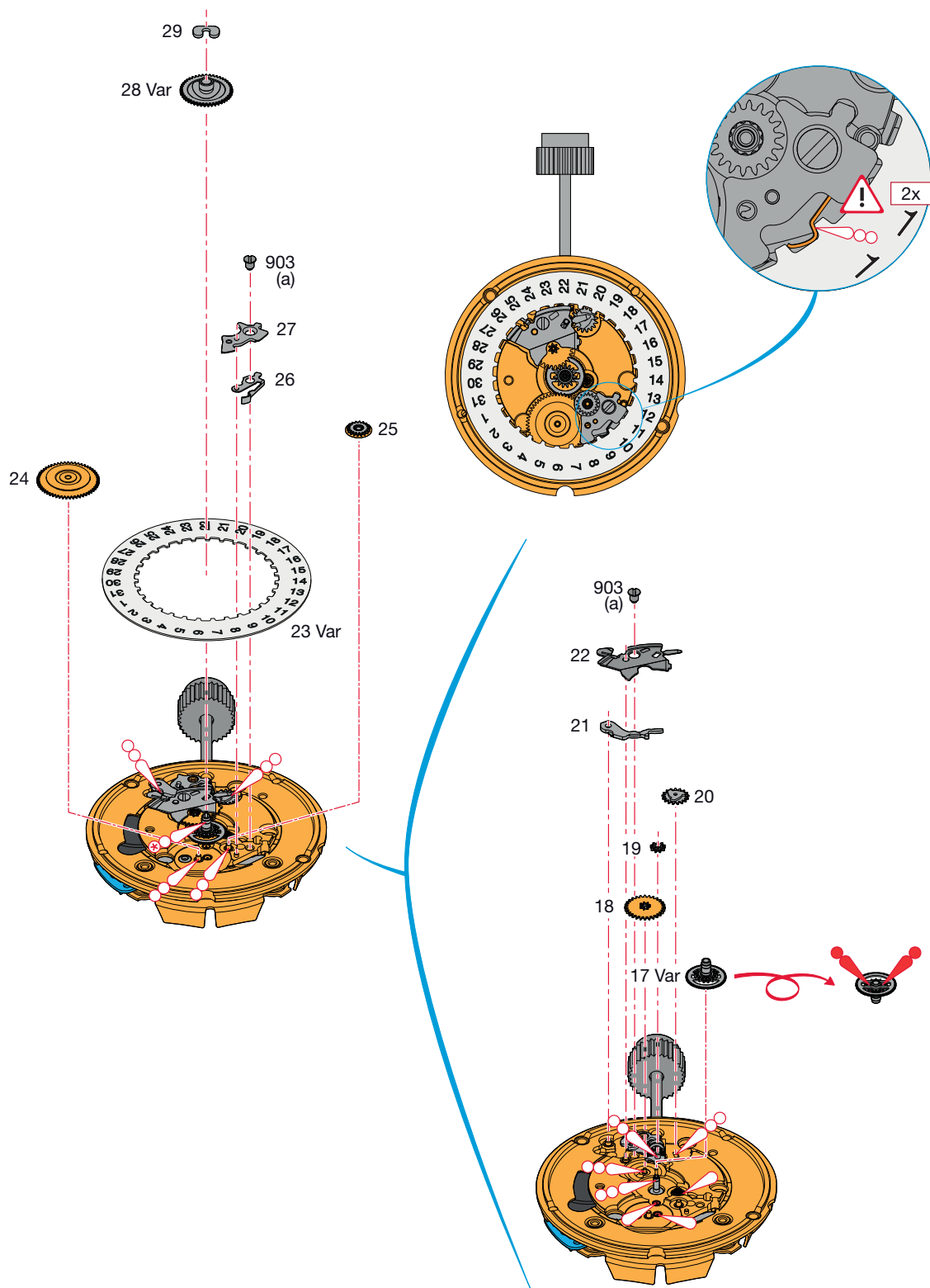

Assembling of the calendar mechanism

(Parts listed in order of assembly)

Montaje del mecanismo de calendario

(Lista de fornitureas por orden de ensamblado)

Montaggio del meccanismo del calendario

(Elenco delle forniture in ordine di montaggio)

17 Var	22	26
18	903 (1x)	27
19	23 Var	903 (1x)
20	24	28 Var
21	25	29

Lubrication - Lubricación - Lubrificazione

 Fine oil
Aceite fino
Olio fluido

Moebius 9014
or / ó / o
Moebius 9034

 Thick oil or grease
Aceite espeso o grasa
Olio denso o grasso

Moebius HP-1300
or / ó / o
Moebius D5

 Very small quantity
Cantidad muy pequeña
Piccolissima quantità

Moebius HP-1300
or / ó / o
Moebius D5

 Grease
Grasa
Grasso

Moebius 9501
or / ó / o
Jismaa 124

M_L Minimum torque for loosening**M_L Par mínimo para desatornillar****M_L Coppia minima per svitare**

(a) 0,7 Ncm



Lubricate part 26.

1. Lubrique la pieza 26.
Lubrificare il pezzo 26.

Rotate part 23 approx 10 teeth with rapide correction.

2. Gire la pieza 23 unos 10 dientes con la corrección rápida.
Ruotare il pezzo 23 di circa 10 denti con la correzione rapida.

Lubricate again part 26.

3. Lubrique de nuevo la pieza 26.
Lubrificare di nuovo il pezzo 26.

Rotate part 23 approx 10 teeth with rapide correction again.

4. Gire de nuevo la pieza 23 unos 10 dientes con la corrección rápida.
Ruotare di nuovo il pezzo 23 di circa 10 denti con la correzione rapida.

Order of assembly - Orden del montaje - Ordine dell'assemblaggio:
Battery - Pila - Pila

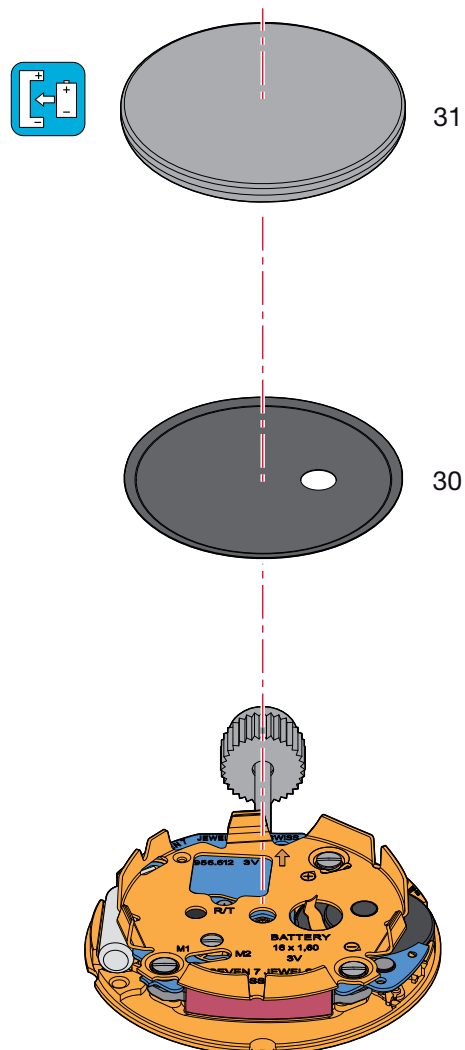

Assembling of the battery

(Parts listed in order of assembly)

Montaje de la pila

(Lista de fornitureas por orden de ensamblado)

Montaggio pila

(Elenco delle forniture in ordine di montaggio)

30

31

Pos. 31:

To be fitted when the clearance between the movement and the case back is too great.



Necesario, si la seguridad entre el movimiento y el fondo de la caja es demasiado elevada.

Necessario quando la sicurezza tra il movimento e il fondo della cassa è troppo elevata.

Electrical tests - Controles eléctricos - Controlli elettrici

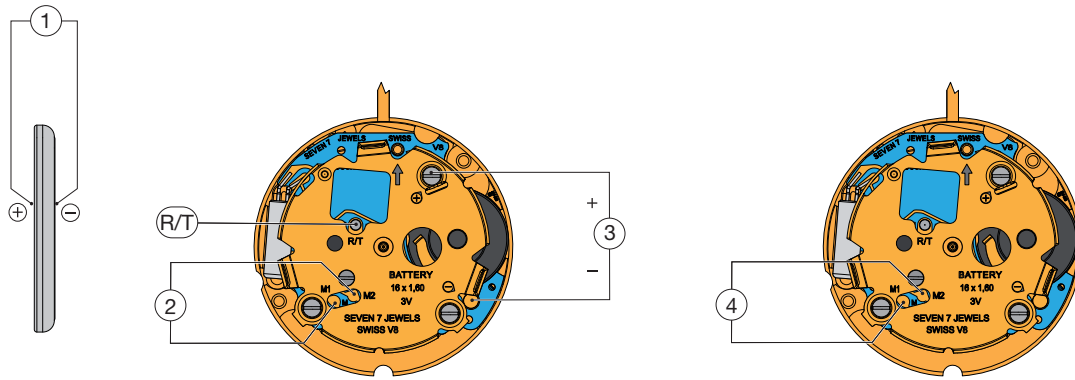

Without battery, with external power supply
Sin batería, con alimentación exterior
Senza batteria, con alimentazione esterna

Without battery, with external power supply
Sin batería, con alimentación exterior
Senza batteria, con alimentazione esterna

Position Posición Posizione	Setting of apparatus Escala de medición Scala di misura	Measurement Medición Misura	Test Control Controllo	Remarks Notas Osservazioni
1	4 V ($R_i \geq 10 \text{ k}\Omega/\text{V}$)	3,00 V	Battery voltage Tensión de la pila Tensione della pila	The tension of the battery should be checked outside the movement. La tensión de la pila debe ser medida fuera del movimiento. La tensione della batteria deve essere misurata fuori dal movimento.
		4 steps jump every 4 sec., when feed voltage < 1.30 V. Salto de 4 pasos cada 4 segundos, con tensión de alimentación < 1,30 V. Scatto di 4 passi ogni 4 secondi quando la tensione e di un'alimentazione < 1,30 V.	EOL function. End of life test for the battery. Función EOL. Prueba de indicación de fin de vida de la pila. Funzione EOL. Prova dell'indicazione di fine vita della pila.	Measurement without battery, with feed voltage < 1.30 V, EOL –function after about 2 min. Medición sin pila, con tensión de alimentación < 1,30 V, EOL –funcionamiento después de 2 minutos. Misura senza pila, con tensione di alimentazione < 1,30 V, EOL –funzionamento dopo 2 minuti.
		Hand of the measuring apparatus oscillates in + and – direction. La aguja del multímetro oscila en sentido + y –. La lancetta del multimetro oscilla nel senso + e –.	Impulses at output of integrated circuit: Frequency 1 Hz. Impulsos a la salida del circuito integrado: Frecuencia 1 Hz. Impulsi all'uscita del circuito integrato: Frequenza 1Hz.	Measurement without battery, with external power supply 2.90 V. Medición sin pila, con alimentación exterior de 2,90 V. Misura senza pila con alimentazione esterna di 2,90 V.
3	4 V	$\leq 1,30 \text{ V}$ Connect R/T point with the – conductor. Motor driven with 16 steps/s at 3.00 V and 32 steps/s with voltage $\leq 2.35 \text{ V}$ (EOL). Conectar el punto R/T con la pista –. Mando del motor con 16 pasos/s a 3,00 V y 32 pasos/s con tensión $\leq 2,35 \text{ V}$ (EOL). Mettere in contatto il punto R/T con il punto –. Comando del motore con 16 passi/s a 3,00 V e 32 passi/s con tensione $\leq 2,35 \text{ V}$ (EOL).	Lower working–voltage limit. Límite inferior de la tensión de funcionamiento. Limite inferiore della tensione di funzionamento.	Measurement without battery, with variable external power supply, starting with 1.55 V, lower tension until movement stops. Medición sin pila, con alimentación exterior variable bajando de 1,55 V hasta la parada de la máquina. Misura senza pila con alimentazione esterna variabile, scendendo da 1,55 V fino all'arresto del movimento.

Position Posición Posizione	Setting of apparatus Escala de medición Scala di misura	Measurement Medición Misura	Test Control Controllo	Remarks Notas Osservazioni
3	10 μ A	$\leq 1,15 \mu$ A	Consumption of movement. Consumo de la máquina. Consumo del movimento.	Measurement without battery, with external power supply 2.90 V. Medición sin pila, con alimentación exterior de 2,90 V. Misura senza pila con alimentazione esterna di 2,90 V.
		$\leq 0,4 \mu$ A	Function of stop lever, pos. 3 of handsetting. Funcionamiento del interruptor en pos. 3 de la tija de puesta en hora. Funzionamento dell'interruttore in pos. 3 dell'albero di massa all'ora.	Measurement without battery, with external power supply 2.90 V. Medición sin pila, con alimentación exterior de 2,90 V. Misura senza pila con alimentazione esterna di 2,90 V.
4	$\sim 10 \text{ k}\Omega$	1,7–2,1 $\text{k}\Omega$	Resistance of motor coil. Resistencia de la bobina del motor. Resistenza della bobina motore.	
<p><i>Ohmmeter with a test voltage exceeding 0.40 V unsuitable, recommended voltage 0.20 V.</i> <i>Ohmiómetros con tensión de medición superior a 0,40 V inapropiados; tensión recomendada 0,20 V</i> <i>Ohmmetri con tensione di misura superiore a 0,40 V sono inadeguati; tensione raccomandata 0.20 V</i></p>				

*The test must be conducted at an ambient temperature of between 20°C and 25°C.
Las pruebas deben realizarse a una temperatura ambiente comprendida entre 20°C y 25°C.
I test devono essere effettuati a temperatura ambiente compresa tra 20°C e 25°C.*

Fitting the battery

Slide the battery against the contact strip
①

Press the battery firmly into its mounting
②. The contact strip keeps the battery in position.

The tweezers must not be electrically conductive!

Colocación de la pila

Colocar la pila debajo de las dos lengüetas metálicas del cubre-módulo ①. Apretar la pila al fondo de su alojamiento ②. El dedo del cubre-módulo sujeta la pila en su sitio.

Las pinzas no deben ser conductoras de la electricidad!

Posa della pila

Far scivolare la pila sotto le due linguette metalliche del copri-modulo ①. Premere la pila al fondo del suo alloggiamento ②. Il dito del copri-modulo mantiene la pila nella sua posizione.

La pinzetta non deve condurre elettricità!

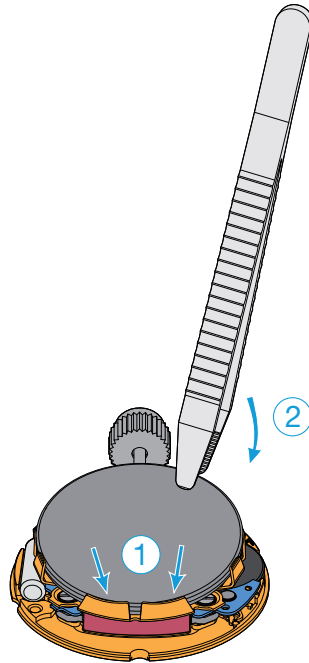

Removing the battery

Insert tweezers ① between main plate and battery (see drawing) and lift out the battery by gently lifting back ②. Remove the battery ③.

The tweezers must not be electrically conductive!

Retiro de la pila

Insertar unas pinzas ① entre el módulo y la pila (véase dibujo) y palanquear la pila apartando cuidadosamente el dedo del cubre-módulo ②. Sacar la pila ③.

Las pinzas no deben ser conductoras de la electricidad!

Ritiro della pila

Far scivolare una pinzetta ① tra il modulo e la pila (vedi disegno) e fare leva sotto quest'ultima allargando leggermente il dito di sostegno verso dietro ②. Ritirare la pila ③.

La pinzetta non deve condurre elettricità!

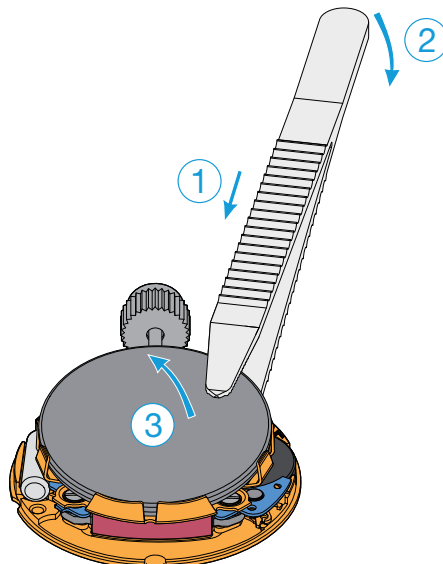

Extracting the stem

The handsetting stem must be pushed back to position 1 (neutral) before pressing on the point lying on the right sider of the setting lever.

Extracción de la tija de puesta en hora

Antes de pulsar el punto a la derecha del tirete, es obligatorio empujar la tija de puesta en hora en posición 1 (neutral).

Estrazione dell'albero di messa all'ora

Prima di premere il punto a destra del tireto, è obbligatorio premere l'albero di messa all'ora in posizione 1 (neutra).

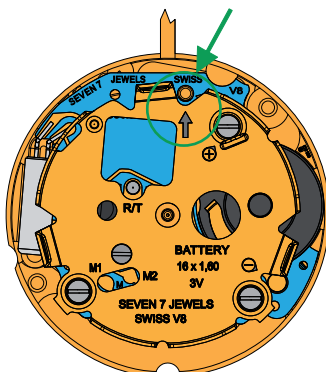

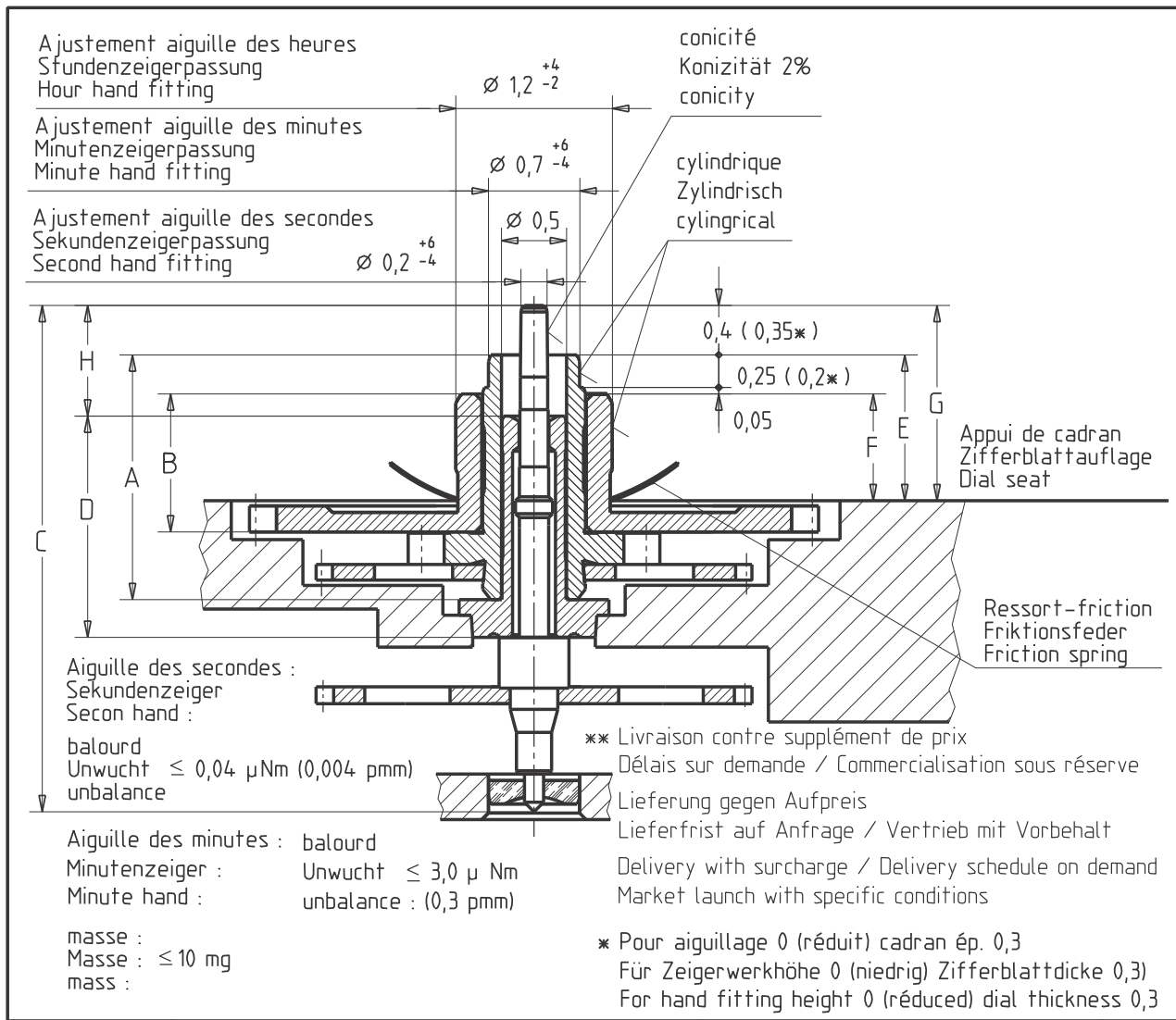

Aiguillage Zeigerwerk- höhe Hand fitting height	Longueur / Länge / Length				Dépassement Höhe über Zifferblattauflage Height over dial seat			H
	A	B	C	D	E	F	G	
Chaussée Minutenrohr Cannon pinion	Roue des heures Stundenrad Hour wheel	Pignon des sec. Sekundentrieb Second wheel pinion	Tube de centre Zentrumrohr Centre tube	Chaussée Minutenrohr Cannon pinion	Roue des heures Stundenrad Hour wheel	Pignon des sec. Sekundentrieb Second wheel pinion		
* réduit niedrig reduced	1,66	0,89	3,63	1,7	0,9	0,65	1,25	0,6
1 normal	1,88	1,06	3,88	1,7	1,1	0,8	1,5	0,85
** 3	2,38	1,56	4,38	1,7	1,6	1,3	2	1,35
** 4	2,63	1,81	4,63	1,7	1,85	1,55	2,25	1,6
** 5	2,88	2,06	4,88	1,7	2,1	1,8	2,5	1,85

Kaliber / Calibre / Caliber 956102/112/152/402/412/612/652 955102/112/402/412/452/612/652	Masstab Echelle Scale		EUCLID321B
		Masse in mm Dimensions en mm Dimensions in mm	Tol. 1/1000 mm

AIGUILLAGES ZEIGERWERKHÖHEN HAND FITTING HEIGHTS	Version 00	Revision 00	Blatt Feuille Sheet 01
Z0038907			

Ersatz für En remplacement de Remplacement for 24.287		Klass. Class. ZVACC	KUN
Aenderung Modification Geprüft Contrôlé Freigegeben Libéré Released		Erstellt Établi Created 03.05.2001 HAM	Geprüft Contrôlé Controlled 24.09.2002 ZWJ
	ETA SA Manufacture Horlogère Suisse CH-2540 Grenchen UNE SOCIÉTÉ DU		

We reserve all rights for this document. It is meant for the recipient only and it may not be copied, printed or given to a third person without our written permission. Quedan reservados todos los derechos relacionados con este documento, que está dirigido únicamente al destinatario. Queda por lo tanto prohibida su copia, impresión o terceros sin nuestra autorización por escrito. Ogni diritto su questo documento è riservato. Il documento è indirizzato esclusivamente al destinatario e non può essere copiato, stampato o ceduto a terzi senza un'autorizzazione scritta.

Cette page est laissée vide
intentionnellement en cas d'impression
au format A3.

Diese Seite wird absichtlich leer
gelassen für den Fall, dass im
A3-Format gedruckt wird.

This page has deliberately been
left blank in case of A3 format
printing.

Cette page est laissée vide
intentionnellement en cas d'impression
au format A3.

Diese Seite wird absichtlich leer
gelassen für den Fall, dass im
A3-Format gedruckt wird.

This page has deliberately been
left blank in case of A3 format
printing.

Cette page est laissée vide
intentionnellement en cas d'impression
au format A3.

Diese Seite wird absichtlich leer
gelassen für den Fall, dass im
A3-Format gedruckt wird.

This page has deliberately been
left blank in case of A3 format
printing.

Modifications compared with previous document versions**Modificaciones comparadas con las versiones anteriores del documento****Modifiche comparate con le versioni precedenti del documento**

Version Versión Version	Date Fecha Data	Modification	Modificación	Modifica	Page Página Pagina
07	14.05.2014	Adaptation variant and GTIN number	Adapación variante y número GTIN	Adattamento variante e numero GTIN	3-11
06	01.06.2012	New illustrations	Nuevas ilustraciones	Nuove illustrazioni	1, 4-5
		New address	Nueva dirección	Nuovo indirizzo	1, 3, 24
		Montage modifications	Modificaciones montaje	Modifiche d'assemblaggio	6-15
05	28.09.2010	Modifications lubrications	Modificaciones lubricación	Modifica lubrificazione	5
04	16.09.2009	Modification lubrication	Modificación lubricación	Modifica lubrificazione	4
		Modification components	Modificación piezas	Modifica componenti	2-3
		New layout	Nuevo layout	Nuova layout	1-12
03	03.04.2007	Basic version	Versión de base	Versione di base	--

All modifications reserved.

Salvo modificación.

Con riserva di ogni eventuale modifica.

This document can be found on the Support Center Portal (SCP):**www.eta.ch**

- Support Center
- Support Center Portal
- Technical Documents

Este documento se encuentran en el Support Center Portal (SCP):**www.eta.ch**

- Support Center
- Support Center Portal
- Technical Documents

Il presente documento si trovano sul Support Center Portal (SCP):**www.eta.ch**

- Support Center
- Support Center Portal
- Technical Documents



ETA^{SA}
MANUFACTURE HORLOGÈRE SUISSE
DEPUIS 1793

SC PRODUCT COMMUNICATION

Bahnhofstrasse 9
2540 Grenchen
Switzerland

Phone +41 (0)32 655 71 11
Fax +41 (0)32 655 71 74

contact@eta.ch
www.eta.ch